

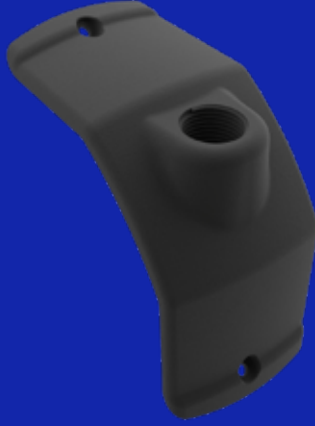

TS EN 50085-1
TS EN IEC 61439-1

5
YEARS
WARRANTY



ARM130.810

2x  **M6 x 12**

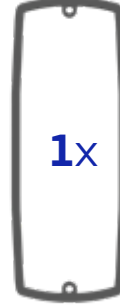

1

Sarı renkli bantı çıkarınız. Yapışkan yüzeyi içeri gelecek şekilde contayı yerleştiriniz.

(Remove the yellow tape. Place the gasket with adhesive surface inside.)

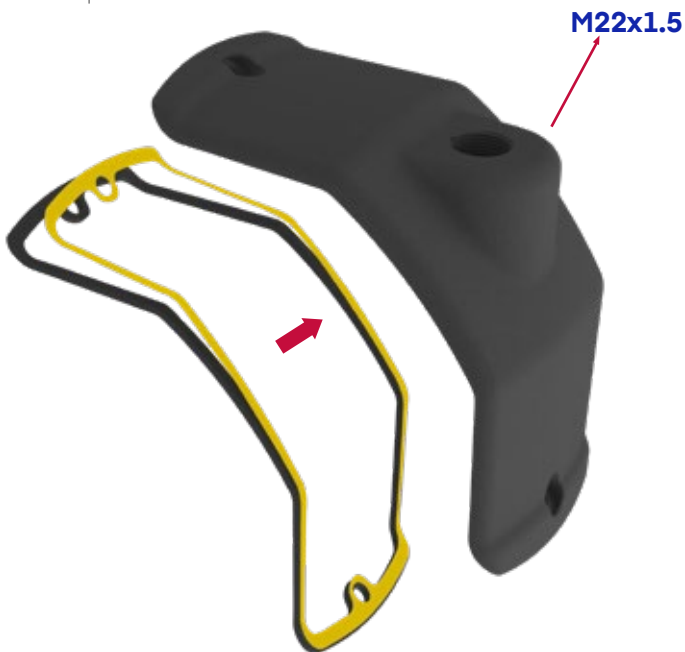

2

Kapakları ve cıvataları görselde ki gibi konumlandırıp montajı yapınız.

(Position and assemble the covers and bolts as shown in picture)

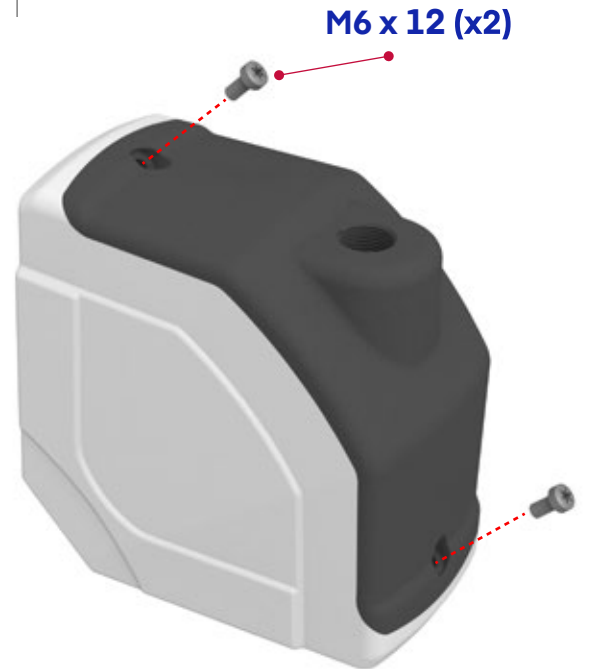

3

İkaz lambasını aşağıya doğru saat yönünde döndürerek takınız.

(Install the warning lamp by turning it clockwise downwards)

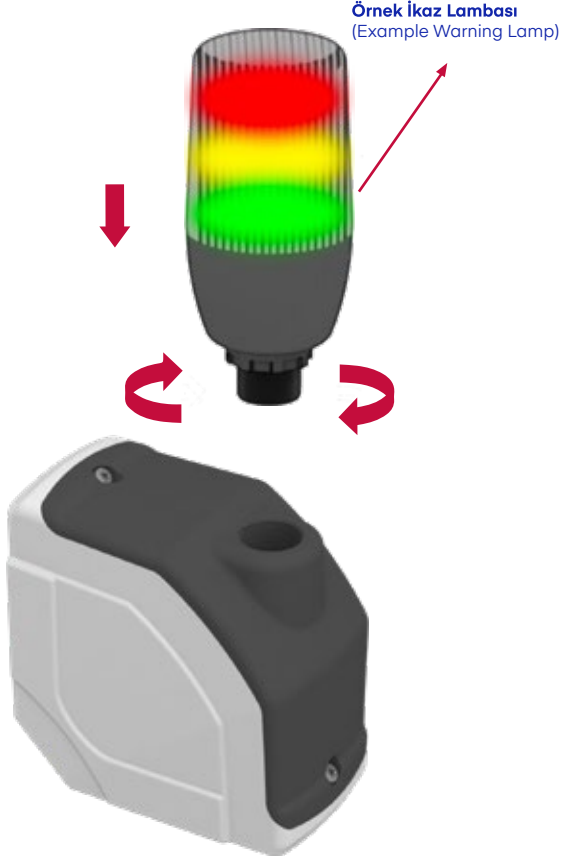

4

Montajın görseldeki gibi talimatlara uygun olarak yapıldığından emin olunuz.

(Make sure that the assembly is done as shown in the picture)

